

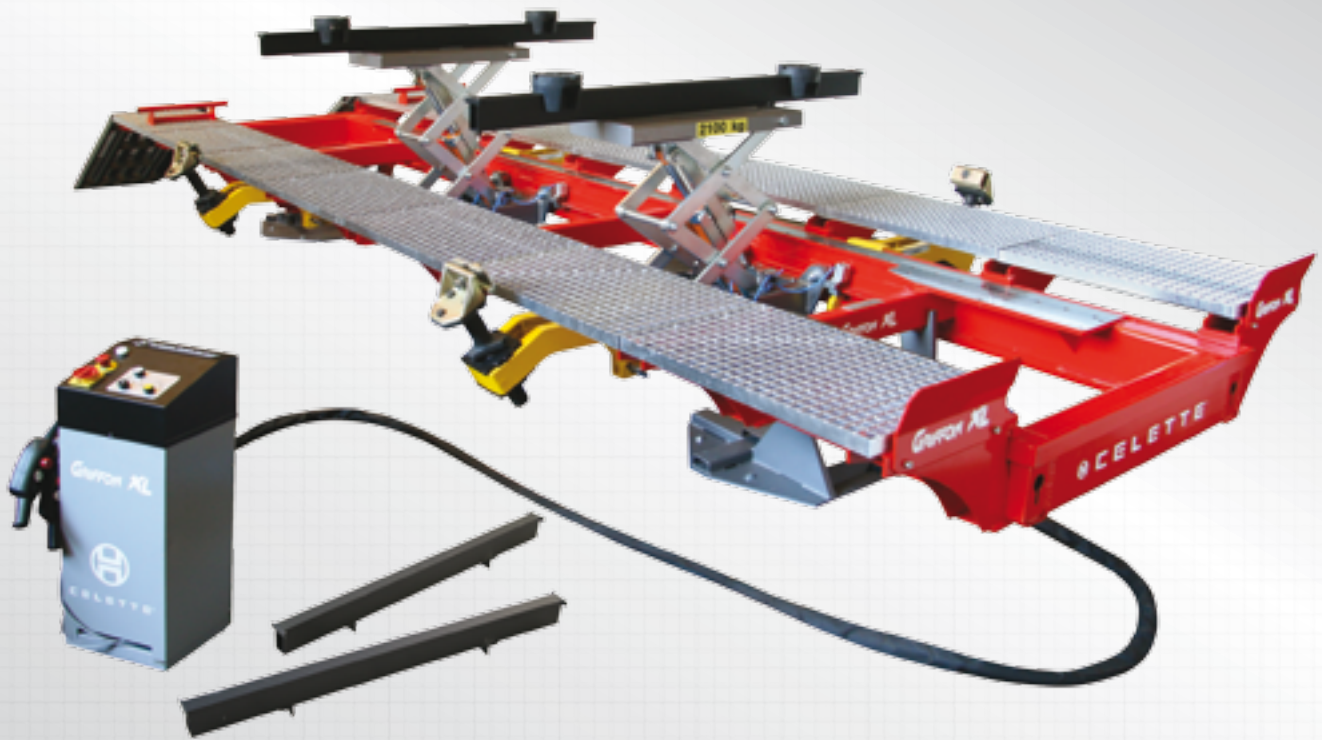

CELETTE®

CAR LIFE SOLUTIONS



GRIFFON XL

*Marbre éleveur long avec double système de levage
Long bench with double lifting system*

GXL08.5812

Le GRIFFON XL mesurant 5.80m de longueur est spécialement adapté aux véhicules utilitaires et SUV. Cette importante longueur permet d'effectuer des réparations simultanées à l'avant et à l'arrière du véhicule. Il est muni de 2 éleveurs internes et indépendants ainsi qu'un basculeur hydraulique permettant d'incliner le marbre.

The 18 ft inch long bench GRIFFON XL is specially designed to repair commercial vehicles and SUV. This length enables you to complete simultaneous repairs at the front and at the rear of the vehicle. This bench is supplied with 2 independent inner lifting units and a hydraulic tilting system.

GRIFFON XL

Marbre élévateur long avec double système de levage
Long bench with double lifting system

GXL08.5812



Références / part number	Description
GXL08.5812	Marbre + Centrale hydraulique + 2 élévateurs internes + 4 pinces d'ancrage + chemin de roulement + élévateur arrière <i>Bench + Hydraulic power unit + 2 inner lifts + 4 anchoring clamps + runway decking plates + rear lifting unit</i>
Références / part number	Options
SVN05.301	Équerre de traction sevenne (10 tonnes) <i>Sevenne pulling unit (10 ton)</i>
GR97.0073	Chariot de mise en place <i>Trolley to position the vehicle on the bench</i>
MZ450.907	Servante de rangement <i>Storage trolley</i>



SVN05.301

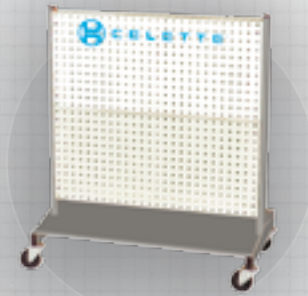

MZ450.907



GR97.0073

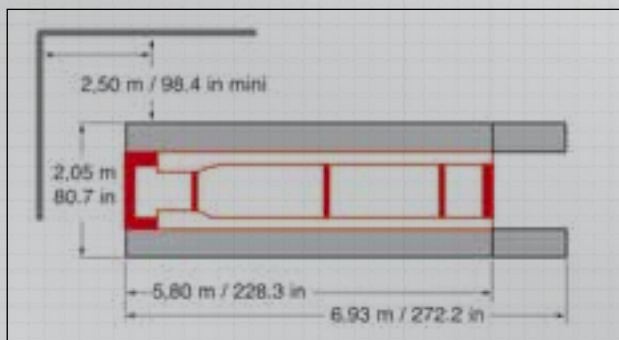

SYSTEMES DE REDRESSAGE / STRAIGHTENING SYSTEM

© Copyright CELETTE S.A. Photos non contractuelles - Reproduction interdite / All modifications reserved - All rights reserved

Doc.403 F-GB/R2 05/10

