



SPHERE

ALIGNMENT



FTS Szerviztechnika Kft.
8600 Siófok Küszhegyi út 11/1.
+36 30 377 93 02
+36 30 74 20 915
info@fts.co.hu

SPHERE ARP3D.HP

SPHERE ARP3D.ATS

**Apparecchi
assetti ruote**

(IT)

**Wheel
aligner**

(EN)

Achsmessgerät

(DE)



3DT® TARGET (Solid Vision Technology)

PATENT PENDING

1,2 kg



**EXTREMELY FAST:
NO COMPENSATION
REQUIRED**

- Esclusivo target con obiettivi 3D:
- permette di evitare la compensazione del fuori centro
 - estremamente leggero
 - **non contiene componenti elettronici**
 - **non richiede manutenzione.**

Exclusive 3D targets:

- no need for run out compensation
- extremely light
- **no electronic components inside**
- **no maintenance required.**

Exklusives Target mit 3D Objektiven:

- keine Felgenschlagkompensation erforderlich
- extrem leicht
- **ohne elektronische Bauteile**
- **wartungsfrei**



**ALIGNMENT
READING IN 8"**



Trasmissione dati tra rilevatori e console via Bluetooth.

Bluetooth transmission between measuring heads and control unit.

Bluetooth-Übertragung zur Konsole.

3 POINT + QUICK LOCKING

PATENT PENDING



FASTEST SETUP

Coppia di griffe autocentranti a 3 punti in appoggio. Fornite di sistema di movimento rapido unghie. Nessun contatto metallo con metallo.

Pair of self-centering 3 point clamps. Equipped with quick claws approach device. No metal-to-metal contact.

Paar selbstzentrierende 3-Punkt Schnellspannhalter. Mit System zur raschen Anpassung der Klauen an den Felgen. Kein Metall-Metall Kontakt.



LIFT LEVEL COMPENSATION



Può essere usato su qualsiasi ponte a 4 colonne o forbice. Compensazione automatica della planarità.

Can be used on any 4 post or scissors lift. Automatic lift level compensation.

Einsetzbar auf alle 4-Säulen- und Scheren-Hebebühnen. Ebenheit der Bühne wird automatisch kompensiert.



2 MODELS / 2 VERSIONS

ARP 3D HP
ARP 3D ATS

ARP 3D HP.B
ARP 3D ATS.B

WIRED POWER SUPPLY



STANDARD

Alimentazione precablata al ponte, per installazione fissa. I rilevatori sono comunque facilmente asportabili.

Power supply pre-wired to the lift, for fixed installation. Sensors can be easily removed at any time.

Feste Installation mit Verkabelung auf der Bühne. Die Messwertaufnehmer sind zu jeder Zeit schnell abmontierbar.

QUICK BATTERY CHANGE



B - VERSION (BATTERY)

A batterie, per installazione fissa o mobile. Batterie a cambio rapido. Connettore per ricarica batterie anche sui rilevatori.

Version with batteries for fixed or mobile installation. Quick battery change. Includes wiring to recharge batteries also on sensors.

Batteriebetrieb, feste oder mobile Installation. Schneller Batteriewechsel. Mit Ladestecker zum Aufladen der Batterie auch in den Messwertaufnehmern.

DIGITAL DISPLAY



GREEN LED: battery under charge/ external powering

RED LED: detector on

DISPLAY: battery level

REMOTE CONTROL

Tastiera con funzione comando a distanza.

Keyboard with remote-control function.

Tastenfeld mit Fernbedienungsfunktion.

LED REPEATER



Regolazioni guidate senza dover guardare il monitor.

Guided adjustments with no need to see the monitor.

Geführter Justagevorgang ohne auf den Bildschirm schauen zu müssen.

LED anteriore/front/vorne

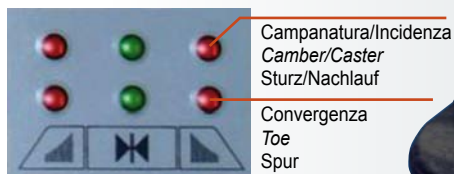

Campanatura/Incidenza
Camber/Caster
Sturz/Nachlauf

Convergenza
Toe
Spur

LED posteriore/rear/hinten

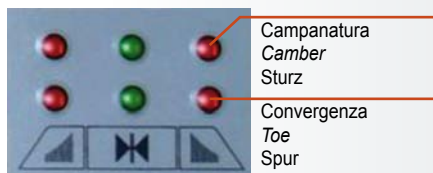

Campanatura
Camber
Sturz

Convergenza
Toe
Spur

TOP PRECISION TARGET READING



MEGAPIXEL HIGH RESOLUTION CAMERAS

STEERING



NO ADAPTER REQUIRED !



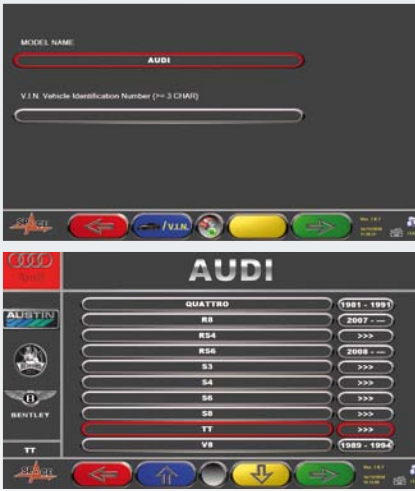

EASY VEHICLE SELECTION

Ricerca veicolo rapida inserendo modello o numero V.I.N.

Quick entering of vehicle by model or V.I.N. number

Schnelle Fahrzeugsuche durch Modell oder V.I.N.-Nummer



Riepilogo e confronto valori diagnosi/riparazione in un'unica videata.

Summary and comparison of diagnosis/repair values on a single screen.

Zusammenfassung und Vergleich der Werte Diagnose/Reparatur auf einer einzigen Seite

3D INFO



EASY DATA



EASY ALIGNMENT



- Programma di gestione e visualizzazione dati in ambiente WINDOWS
- Banca dati con oltre 90.000 schede tecniche veicolo
- Possibilità di ulteriore inserimento di schede da parte dell'utilizzatore
- Banca dati clienti per la registrazione di 20.000 interventi con ricerca per nominativo o numero di targa veicolo

- *Data management and display program in WINDOWS environment*
- *Data bank with more than 90.000 vehicle data sheets*
- *Further data sheets can be added by the user*
- *Customer data bank for recording 20.000 jobs with search by customer name or vehicle plate number*

- Managementprogramm und Datenanzeige in WINDOWS
- Datenbank mit mehr als 90.000 Fahrzeug-Datenblättern
- Möglichkeit der Eingabe von weiteren Datenblättern durch den Benutzer
- Kundendatenbank für die Aufzeichnung von 20.000 Eingriffen mit Suchfunktion nach Kundennamen oder Fahrzeug-Kennzeichen

EASY UPDATE



SMART CARD per aggiornare velocemente la banca dati.
CHIAVE USB per salvataggio e ripristino dei dati cliente.

*SMART CARD for quick data bank update.
USB KEY to save and restore customer data.*

SMART CARD für ein schnelles Datenbank-Update.
USB-STICK um Kundendaten zu speichern bzw. wiederherzustellen.

RUN OUT COMPENSATION WHEN REQUIRED



Misurazione del fuori centro quando richiesto*.

Run out compensation when required.*

Rundlaufkorrektur wenn gewünscht*.

* Ø 500mm	→	150mm
Ø 600mm	→	170mm
Ø 700mm	→	200mm
Ø 800mm	→	230mm

USUAL 3D

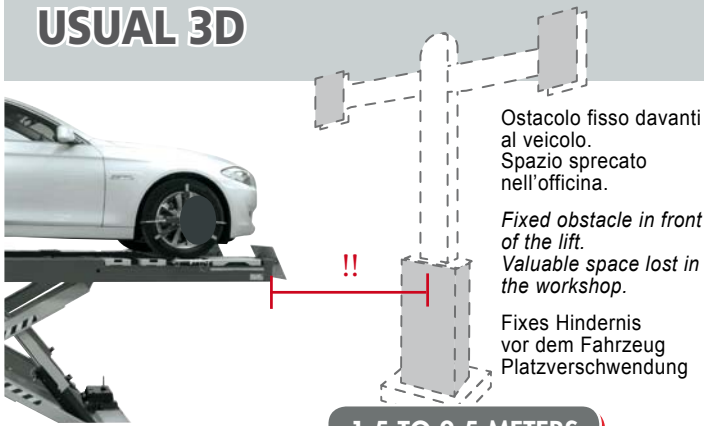

Ostacolo fisso davanti al veicolo. Spazio sprecato nell'officina.

Fixed obstacle in front of the lift. Valuable space lost in the workshop.

Fixes Hindernis vor dem Fahrzeug Platzverschwendung

1.5 TO 2.5 METERS LOST SPACE

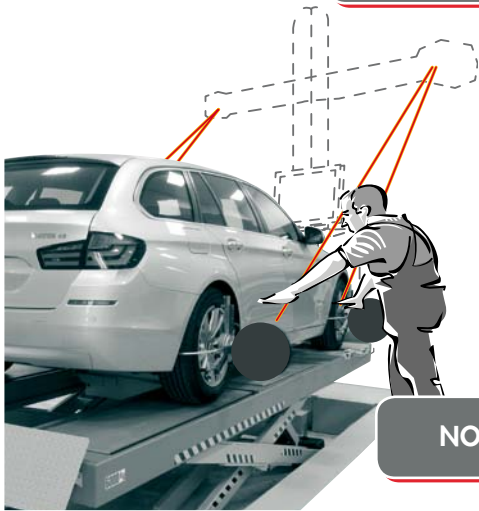

Trasmissione spesso interrotta durante il lavoro

Frequent interruption of transmission signal.

Der Arbeitsvorgang kann die Verbindung unterbrechen

NO SIGNAL

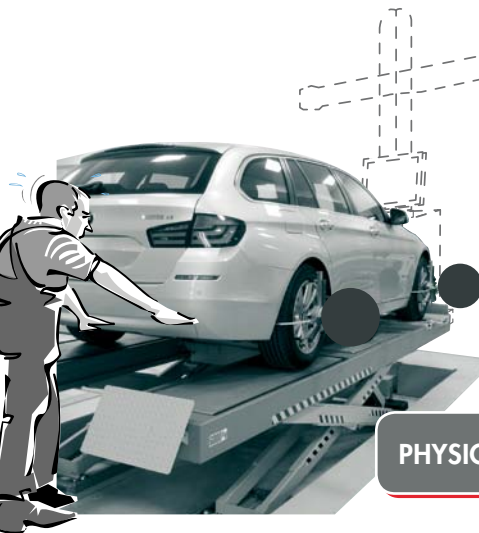

Obbligo di spingere il veicolo indietro e avanti

Requires vehicle to be pushed back and forth to produce measurements.

Rundlaufkorrektur ist immer erforderlich

PHYSICAL EFFORT



Una sola postazione per assetto ruote. Una sola altezza di lavoro.

Limited to use in only one alignment bay. One working height only.

Eine fixe Vermessungsstelle

ONE LIFT ONLY, ONE HEIGHT ONLY

Nessun ostacolo al passaggio, (consolle su rotelle). Ottimizzazione dello spazio in officina.

Portable aligner console can be positioned anywhere for ultimate convenience. Maximizes available workspace.

Kein Hindernis vor dem Fahrzeug Platzsparend

NO OBSTACLE



Trasmissione sempre garantita

Perfect transmission signal always.

Keine Unterbrechung während des Arbeitsvorganges

NO INTERRUPTION



Rilevamento automatico target 3D. Non serve spingere il veicolo

No rolling or pushing of the vehicle to make runout compensation. Automatic and instant 3D target visualization.

Dank der 3-D-Datenerfassung keine Rundlaufkorrektur erforderlich

NO COMPENSATION



Possibilità di lavorare su diversi ponti (con attacchi rapidi opzionali). Utilizzo a qualsiasi altezza.

Use the aligner in more than one bay location (optional supports required). Can be used at any height.

Mobil einsetzbar. Verschiedene Messplätze möglich.

NO LIMITATION



ARP 3D HP ARP 3D HP.B

Modello a camere fisse.
Dotato di grappe a 3 punti in appoggio per evitare la compensazione del fuori centro.
Utilizzo molto rapido.
Tastiera telecomando su ogni rilevatore.
Compensazione del fuori centro non obbligatorio.

*Version with fixed cameras.
Equipped with tire grabbing 3 point clamps to avoid run out compensation.
Very quick to use.
Remote control located on each sensor.
Run out compensation when required.*

Modell mit festen Kameras.
Mit kompensationsfreien 3-Punktschnellspannhaltern.
Sehr schnelle Bedienung.
Fernbedienung mit Tastatur an allen Messwertaufnehmern.
Felgenschlagkompensation Wenn Gewünscht.



4 supports standard



monitor 22"

MOBILE AND SAFE



4 kg

Aggancio rapido al ponte.
Pivottante per evitare danni in caso di ostacoli in discesa.

Quick clamp to the lift. Pivoting support to avoid damage with obstacles while lowering.

Schnellsteckhalterung auf der Hebebühne. Nach oben frei beweglich, um Schäden bei Hindernissen auf der Abfahrt auszuschließen.

COMPACT AND ADJUSTABLE

La base del rilevatore può traslare verso l'esterno di 65 mm per veicoli extra larghi.

The base of the sensor can be translated outward by 65 mm in case of extra large vehicles.

Die Halterungen kann bei Bedarf (breiten Fahrzeugen) bis zu 65 mm rausgezogen werden.

ARP 3D HP - FIXED CAMERAS

POSITION A

Misurazione veicoli con passo fino a 4300 mm.

Measurement of vehicles up to 4300 mm (170") wheelbase.

Vermessung von Fahrzeugen bis 4300 mm Radstand.

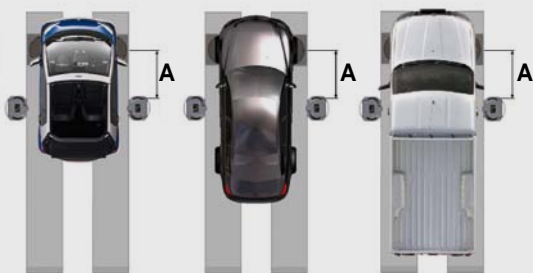

POSITION B

Misurazione veicoli con passo fino a 4700 mm:

- spostare avanti il piatto rotante
- con piatti a posizione fissa, spostare i rilevatori sul secondo supporto (di dotazione)

Measurement of vehicles up to 4700 mm (185") wheelbase:

- move forward the turntables or
- mount the sensors in the second set of supports (standard)

Vermessung von Fahrzeugen bis 4.700 mm Radstand:

- Drehteller ganz nach vorne versetzen
- bei Drehtellern mit fixer Position den Messwertaufnehmer auf zweiter Halterung positionieren





ARP 3D ATS ARP 3D ATS.B

Modello con ricerca automatica dei target.
Rilevatori automatici con orientamento automatico delle camere.
Dotato di graffe a 3 punti in appoggio per evitare la compensazione del fuori centro.
Utilizzo estremamente rapido.
Tastiera telecomando su ogni rilevatore.
Compensazione del fuori centro non obbligatorio.
Fornito di un secondo set di batterie a cambio rapido (ATS.B).

*Model featuring the automatic research of the targets.
Automatic sensors with automatic positioning of the cameras.
Equipped with tire grabbing 3 point clamps to avoid run out compensation.
Extremely fast.
Remote control located on each sensor.
Run out compensation when required.
Equipped with a second set of batteries for quick change (ATS.B).*

Modell mit automatischer Targetsuche.
Automatische Messwertaufnehmer mit automatischer Kameraausrichtung.
Mit kompensationsfreien 3-Punktschnellspannhaltern.
Sehr schnelle Bedienung.
Fernbedienung mit Tastatur an allen Messwertaufnehmern.
Felgenschlagkompensation Wenn Gewünscht.
Mit zweitem Batteriesatz zum schnellen Auswechseln (ATS.B).



monitor 22"



Una comoda apertura a scomparsa protegge la tastiera.
A useful cover can be opened and closed easily to protect the keyboard.
Bedienerfreundliches Ablagefach für die Tastatur.

PATENT PENDING



Rilevatori automatici con orientamento automatico delle camere.
Automatic sensors with automatic positioning of the cameras.
Automatische Messwertaufnehmer mit automatischer Kameraausrichtung.

ARP 3D ATS - REAR CAMERA WITH AUTOMATIC MOTOR-DRIVEN MOVEMENT



La posizione interna o esterna delle camere viene settata automaticamente dal sistema.
Internal or external position of the cameras is automatically set by the system.
Die interne und externe Position der Kameras werden vom System automatisch durchgeführt

SPHERE LIGHT

Consente la massima libertà di utilizzo dell'assetto ruote. Il programma è caricato su un PC portatile che può essere posizionato dove è più comodo nell'officina.

Allows maximum freedom when using the aligner. The program is loaded on a lap top PC which can be placed anywhere in the workshop.

Ermöglicht maximale Freiheit im Einsatz. Laptop mit gespeicherter Vermessungssoftware kann x-beliebig in der Werkstatt positioniert werden.



COMPANY WITH QUALITY MANAGEMENT
SYSTEM CERTIFIED BY DNV
= ISO 9001:2008 =

SPHERE PIT

Pratico utilizzo su fossa tramite due piastre di aggancio fissate al pavimento. I rilevatori possono essere rimossi in qualsiasi momento.

Very practical use on pit, thanks to two flat supports fixed to the floor. Sensors can be removed at any time.

Praktischer Einsatz auf Grube mittels zwei flacher Halterungen am Boden befestigt. Messwertaufnehmer können zu jeder Zeit schnell und einfach entfernt werden.

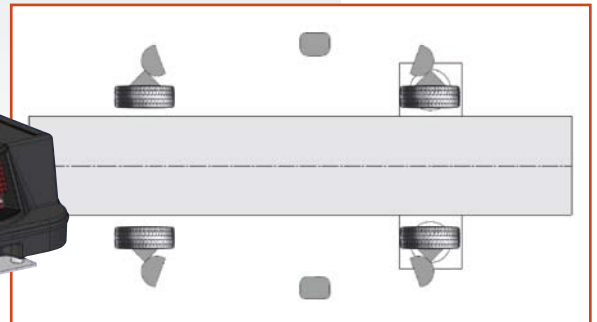

Standard

- 1 console completa di computer, tastiera, monitor, stampante
- 2 rilevatori
- 4 graffe con target
- 1 coppia piatti rotanti
- 1 premipedale
- 1 bloccasterzo
- Manuale istruzioni su CD
- 1 control unit with PC, monitor, key-board, printer
- 2 measuring heads
- 4 clamps with target
- 1 pair of turn tables
- 1 brake pedal depressor
- 1 steering wheel lock
- Instruction manual on CD
- 1 Fahrzeug mit PC, Tastatur, Bildschirm, Drucker
- 2 Messköpfe
- 4 Radhalter mit Target
- 1 Paar Drehteller
- 1 Bremsfeststeller
- 1 Lenkradfeststeller
- Bedienungsanleitung auf CD



STDA117
(2 x kit)

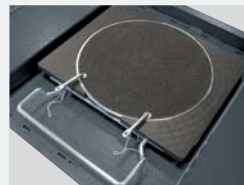

STDA124
(2 x kit)
Piatti rotanti
Turntables
Drehplatten



Caratteristiche Tecniche	Technical Features	Technische Eigenschaften	Precisione Accuracy Messgenauigkeit	Campo di misura Measuring range Messbereich	Campo totale di misura Total measuring range Gesamtmessbereich
Asse anteriore	Front axle	Vorderachse			
Convergenza	Total toe	Gesamtspur	+/- 2'	+/- 2°	+/- 20°
Semiconvergenza	Partial toe	Einzelspur	+/- 1'	+/- 1°	+/- 20'
Deviazione asse	Set-back	Radversatz	+/- 2'	+/- 2°	+/- 5°
Inclinazione ruota	Camber	Radsturz	+/- 2'	+/- 3°	+/- 10°
Incidenza montante	Caster	Nachlauf	+/- 5'	+/- 10°	+/- 18°
Inclinazione montante	King pin	Spreizung	+/- 5'	+/- 10°	+/- 18°
Asse posteriore	Rear axle	Hinterachse			
Convergenza	Total toe	Gesamtspur	+/- 2'	+/- 2°	+/- 20°
Semiconvergenza	Partial toe	Einzelspur	+/- 1'	+/- 1°	+/- 20'
Deviazione asse	Set-back	Radversatz	+/- 2'	+/- 2°	+/- 5°
Inclinazione ruota	Camber	Radsturz	+/- 2'	+/- 3°	+/- 10°
Angolo di spinta	Thrust angle	Fahrachswinkel	+/- 2'	+/- 2°	+/- 5°

Options

STDA 118 (→ VERSION.B)

Kit di 2 cavi di alimentazione di emergenza
2 cables for emergency power supply
2 Notversorgungskabeln

STDA 128 (→ ARP 3D HP.B)

Kit addizionale di 2 batterie
Additional 2 batteries set
Paar Batterien

STDA23C, STDA24C

Rilevatori RMS
RMS device
RMS Höhen- und Neigungsmessvorrichtung

STDA 119

Kit di misura dinamica altezza veicolo
Live ride height measurement kit
Dynamische Höhenmessvorrichtung

SPACE s.r.l. a s.u.

Via Sangano, 48
10090 Trana - Torino - ITALY
tel. +39-011-934.40.300
fax +39-011-933.88.64
e-mail: info@spacetest.com
www.spacetest.com

FTS Szerviztechnika Kft.
8600 Siófok Küszhegyi út 11/1.
+36 30 377 93 02
+36 30 74 20 915
info@fts.co.hu

Le caratteristiche tecniche e gli allestimenti presentati in questo prospetto possono subire variazioni. Le immagini riprodotte non sono vincolanti.

Technical data and composition presented in this catalogue may vary.
Pictures reproduced are only indicative.

Die techn. Daten und die Ausrüstungen, die in diesem Prospekt enthalten sind, können Änderungen erfahren. Deshalb sind die Abbildungen unverbindlich.



good energy PROPERLY ALIGNED VEHICLES HAVE LOWER TYRE WEAR AND REDUCED FUEL CONSUMPTION